

Cabinet Manufacturing – Fact Sheets



WHAT KIND OF WORK DO PEOPLE DO IN THE KITCHEN CABINET MANUFACTURING PLANT?

Manufacturing kitchen cabinets is a complex process that consist of many operations and require many skills. Among the various operations we selected three as the most representative:

- Shaping: representative of tasks involving the operation of machinery.
- Sanding: repetitive tasks involving excessive bodily motions.
- Assembling: tasks involving the use of different tools in a variety of work positions.

What are some health and safety hazards for cabinet manufacturers?

- Exposure to paints, solvents, and other toxic chemicals or materials.
- Working with hand tools, powered tools and heavy powered equipment, such as woodworking machines.
- Excess vibration in the hands, arms or body from powered tools or equipment.
- Noise.
- Electrical hazards.
- Hazardous energy control including lockout/tag out.
- Working with material handling equipment.
- Slips, trips, and falls.
- Respiratory hazards from wood dust.
- Fire hazards or explosions of combustible dusts.
- Stress.
- Shift work or extended work days.
- Working alone.

In addition to some of the hazards listed above, pain or injury from physical overexertion, repetitive manual tasks, or working in awkward positions is very common. A case study is presented below.

What are some preventive measures for cabinet manufacturers?

- Scan the workplace for existing and potential hazards before work begins and take appropriate controls. Be aware that conditions can change

constantly.

- Inspect all equipment and machinery for any defects before work begins.
- Keep tools and equipment in good working order.
- Use correct personal protective equipment and apparel, including safety footwear.
- Keep all work areas clear of clutter and equipment.
- Practice good housekeeping.
- Avoid awkward body positions or take frequent breaks.
- Learn safe lifting techniques.
- Have training before beginning any task, especially high risk activities such as using power tools and equipment, hazardous energy control (lockout/tag out), etc.
- Know how to get help in an emergency for working alone situations.
- Be aware of the emergency response plans before work begins.
- Know how to report a hazard.
- Stay informed about chemical hazards and WHMIS 2015.

Cabinet Manufacturing: WMSD Prevention Case Study

The following case study reviews the steps of cabinet manufacturing and associated ergonomics risk factors for work-related musculoskeletal disorders (WMSDs).

What are the tasks in Shaping?

The shaping operation consists of modelling pieces of wood with a shaper according to the style of kitchen cabinet being made (Figure 1).

To complete a task a worker has to:

- Pick up pieces of wood.
- Place wood on the shaper.
- Press and push the wood sideways on the shaper.
- Pile pieces of wood for further processing.

The task lasts approximately three seconds. The task is done while standing on a concrete floor.



Figure 1 – Wood shaping

What are the risk factors of Shaping?

Highly repetitive movements, excessive force while pressing wood objects on the shaper, and exposure to vibration put the workers at risk for work-related musculoskeletal disorders (WMSDs). The wrists, neck and shoulders are at the

highest risk. In addition, prolonged standing in a stooped position and repetitious side motions can contribute to low back injuries. T

Prolonged standing on a concrete floor can contribute to lower leg and back discomfort that, over time, can develop into injuries.

All of these factors have a compounding effect. In other words, each of them increases the effects of the others.

What are the tasks in Sanding?

The sanding operation consists of smoothing the surface of wooden sheets by using a hand-operated power sander (Figure 2). The worker uses both hands to carry out this task. The dominant hand is used to operate the sander while the other hand is used to hold the sheet of wood (Figure 3). To complete a task a worker has to:

- Pick up wooden sheets.
- Place the sheets on work bench.
- Sand the sheets.
- Pile the sheets for further processing.

Sanding requires excessive movements such as bending and reaching while keeping the elbow above the shoulder level. Forceful movements are used to hold both the sander and the sheet of wood. Sanding is done in a standing position.

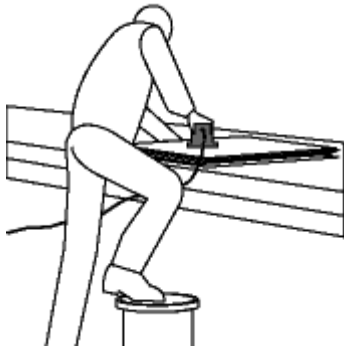

Figure 2 – Sanding

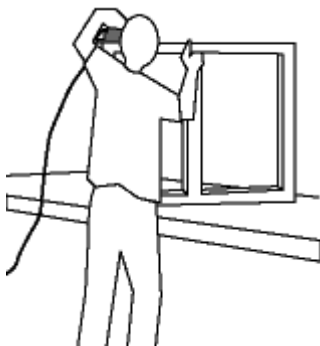

Figure 3 – Sanding

What are the risk factors of Sanding?

Sanding exposes workers to a high risk for repetitive motion injuries. Hands, neck and shoulders are at the highest risk for WMSDs. The high mechanical stress

due to repetitive and forceful movements while operating the sander and the sustained muscular effort to hold work objects are responsible for such a high risk.

Repetitive and forceful movements, and exposure to vibration also put the elbow and wrist of the operating hand at a high risk for WMSDs. The prolonged stooped standing position and excessive and forceful bending create a risk for low back injury.

What are the tasks in Assembling?

Assembling all the components that will form a kitchen cabinet involves the use of various tools such as staplers, screwdrivers and hammers. Assembling kitchen cabinets is a manual operation requiring many steps and many skills. While assembling, workers use a variety of body positions such as bending, twisting and reaching (Figure 4, 5, 6, 7, 8). They also have to stoop and crouch while working (Figure 9).

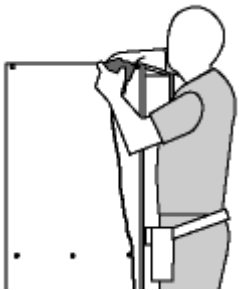

Figure 4 – Assembling kitchen cabinets

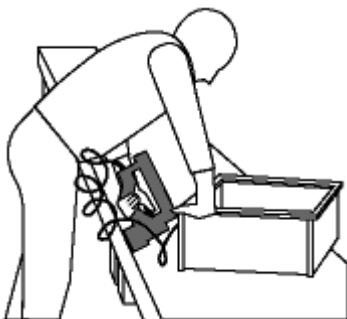

Figure 5



Figure 6

Figures 5 and 6 – Bending while assembling kitchen cabinets

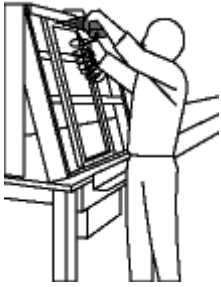

Figure 7



Figure 8

Figures 7 and 8 – Reaching while assembling kitchen cabinets

What are the risk factors of Assembling?

The assembly tasks at a kitchen cabinet manufacturing plant create the conditions that favour the development of WMSDs, as well as low back problems. Operating heavy tools in very awkward body positions (Figure 9, 10, 11), and exerting forces in an off line direction are extremely hazardous for WMSDs of the upper limbs.

The neck and shoulders are also at risk for WMSDs. Whole body motions and lifting, while handling assembled cabinets, put workers at risk for back injuries.



Figure 9 – Awkward body position used while assembling kitchen cabinets

Continuous standing on a concrete floor can cause lower leg and back discomfort that, over time, can develop into injuries.

All these factors have a compounding effect. In other words, each of them increases the effects of the others.



Figure 10

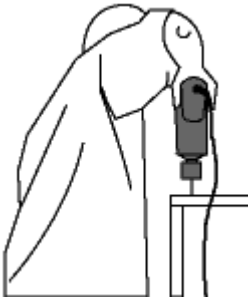

Figure 11

Figures 10 and 11 – Using heavy tools in very awkward body position

How can we reduce the risk factors for WMSD?

General

The three tasks that were selected for examination in the kitchen cabinet manufacturing plant pose similar risks for repetitive motion injuries. However, these three tasks require different approaches for controlling the risk for WMSDs.

Shaping

The working position is the major hazard for WMSDs while shaping. This can be improved by providing:

- More leg clearance – Allow the worker to get closer to the work area, thereby reducing bending (Figure 12).
- Sit/stand stools and foot rests – This would increase the flexibility of the work position and reduce stress on the lower back and legs.
- Consider wearing anti-vibration gloves. However, you should not wear thick or heavy gloves if operating the tool requires precise movements.
- Anti-fatigue matting – This would reduce lower leg and back discomfort from prolonged standing.

Implementation of a full-scale rotation of tasks would improve the working conditions even more.

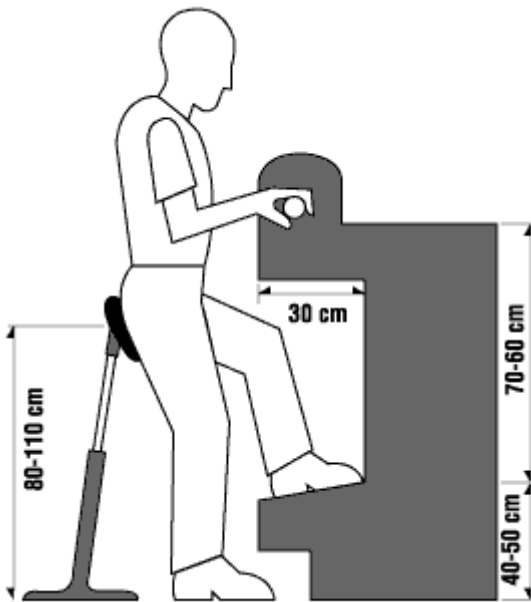

Figure 12 -Working in a standing position
with adequate leg clearance and sit/stand stool

Sanding

Awkward body positions and forceful movements are the major risk factors for WMSDs. Prolonged standing creates lower leg and back discomfort. These conditions can be improved by making these changes:

- Provide sanders with tilted work surfaces, equipped with easy-to-operate devices (Figure 13).
- Using jigs (Figure 14) would substantially reduce the effort of holding work objects; bending would also be reduced.
- Provide workers with footrests to further improve working posture.
- Use anti-fatigue matting to reduce discomfort from prolonged standing.
- Consider wearing anti-vibration gloves. However, you should not wear thick or heavy gloves if operating the tool requires precise movements.
- Select low vibration sanders to further reduce the effects of vibration.

The physical effort required while sanding can be rather strenuous and repetitive. It seems that improvements can be achieved by re-designing the task and by introducing task rotation, or enrichment and enlargement of the task.



Figure 13 – A tilted work surface

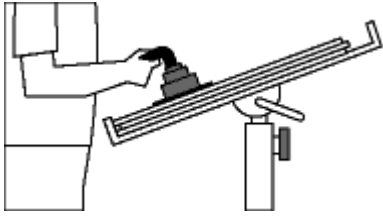

Figure 14 – A jig to hold the work object

Assembling

In the assembly operation, awkward postures and forceful movements are the major risk factors for WMSDs. Vibration and stress due to prolonged standing also contribute to the development of WMSDs.

To reduce awkward body positions, use jigs and fixtures to hold the work object (Figure 15). A fixture that allows the worker to rotate the kitchen cabinet, for example, reduces over-reaching and reduces the handling of the kitchen cabinet.

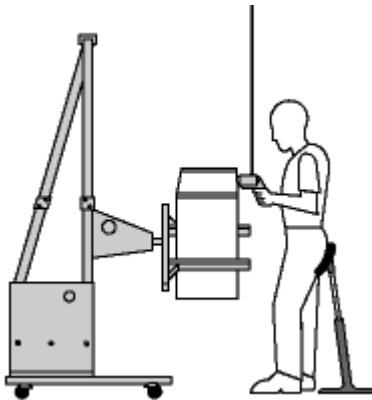

Figure 15 – A fixture holding the work object

It is also important to select the proper tool for the task. Matching the tool to the task reduces awkward postures of the wrist, elbow, and shoulder (Figure 16).

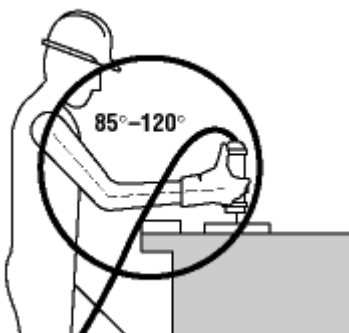

Figure 16 – Selecting the right tool for the task

Using tool balancers reduces the amount of force necessary to hold and operate the tool (Figure 17).

To reduce stress on the legs and back from prolonged standing, workers should use anti-fatigue matting.

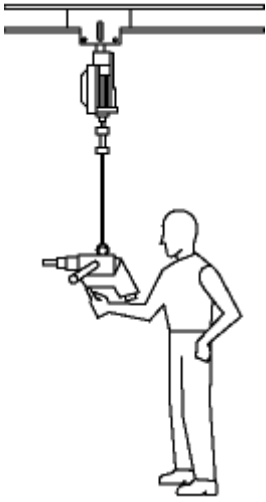

Figure 17 – Using a tool balancer for a heavy too

Source: © Copyright 1997-2021 CCOHS